

Robotic Pool Cleaner User Manual

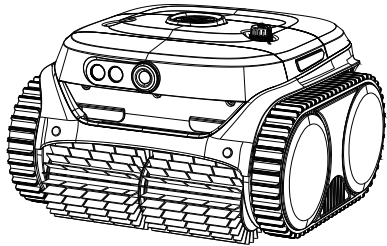

WYBOT C2Pro Vision

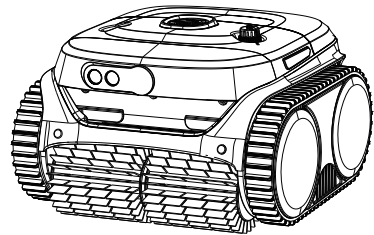

WYBOT C2Pro

WYBOT®

Read through the entire manual before running your new robotic pool cleaner, and keep this manual handy for your reference.

WYBOT®

www.wybotpool.com

E-mail: support@wybotpool.com

Facebook: @WybotPool

WYBOTICS CO.,LTD

No.30,Zhongnan 4th Street West Zone,TEDA Tianjin,China

All trade names are registered trademarks of respective manufacturers listed.





Thank you for choosing WYBOT products, your support means a lot to us. Continuous providing the best solution to free you up from pool cleaning and enjoy your family time is always our pursuit.

WYBOT Robotic Pool Cleaner is dedicated to serving you high efficiency, low power consumption, easy operation and thorough pool cleaning work.

Its unique appearance and reliable functions as one-button activation, powerful suction and scrubbing, fine filtration, smart navigation, remote control, and high compatibility with various pool shapes and constructions materials assure you a convenient, intelligent, and optimal pool cleaning.

Feel free to contact us by Email or visit our website with any questions. We are very glad to hear your advice on our continuous improvement.

Safety Instructions

Warning

Read the manual carefully before you use the cleaner. Your safety is the most important thing. Please read through and operate the device as per instructions, WYBOTICS Co., Ltd. is not held liable for any loss or injury caused by improper use.

Failure to operate the device as per the warnings can result in serious injury, electrocution or death.

1. Use only the accessories recommended or sold by WYBOTICS Co., Ltd.
2. Use only the original and authorized charger. Avoid charging any other types of devices with this charger. Improper use may result in overheating or corrosive liquid leakage from the battery.
3. Power off the robot when doing any maintenance or removing it from the pool.
4. Ensure the charging port is dry before plugging in the charger end.
5. Make sure the electrical outlet is protected by a ground fault circuit interrupter (GFCI) and an earth leakage interrupter (ELI).
6. Do not use a cord-damaged charger to avoid any electrical shock.
7. Do not try to use nonauthorized extension cord to connect the charger to the robot.
8. Never allow children to ride on the cleaner/docking station or play with it as a toy.
9. Do not allow child to operate or maintain the device or docking station.
10. Do not enter the pool when the robot is working in it.
11. Never expose or charge the device in flammable environments.
12. Only licensed professionals can disassemble the sealed parts of the robot.

Safety Instructions

Cautions

Failure to operate the device as per the cautions can cause a damage to the device.

1. Charge the unit before first use.
2. Do not over charge the cleaner, which will reduce the battery life.
3. Charge the cleaner prior to being stored for a long time (over 6 months) to maintain an optimal battery life.
4. Do not operate the cleaner while pool filter is running.
5. Remember to wash and clean the filter basket and HEPA after each use.
6. Store the cleaner in a cool and ventilated place, away from direct sunshine or any heat source.
7. Use only the pool cleaner in the following water conditions:

Chlorine	Max 4 mg/L
pH	7.0 - 7.8
Temperature	41 - 95 °F (5 - 35 °C)
NaCl	Maximum 5000 PPM

CONTENTS

01 / WYBOT AT A GLANCE	01
Product External Overview	01
Product Internal Overview	02
Packing List	03
02 / GET STARTED	04
Charge your new WYBOT	04
Setup your new WYBOT	06
<i>Connect to your App</i>	06
<i>Choose your cleaning mode</i>	07
Run your new WYBOT	08
<i>Dirt hunting mode (special for WYBOT C2Pro Vision)</i>	09
03 / DO A FILTER CLEANING	11
04 / DEVICE SPECIFICATION	12
05 / LIMITED WARRANTY	13
06 / HOW TO MAINTAIN YOUR DEVICE	13
07 / FAQ & TROUBLE SHOOTING	14
08 / CERTIFICATION	16
09 / WYBOT CUSTOMER CARE	16

01 / WYBOT AT A GLANCE

Product External Overview

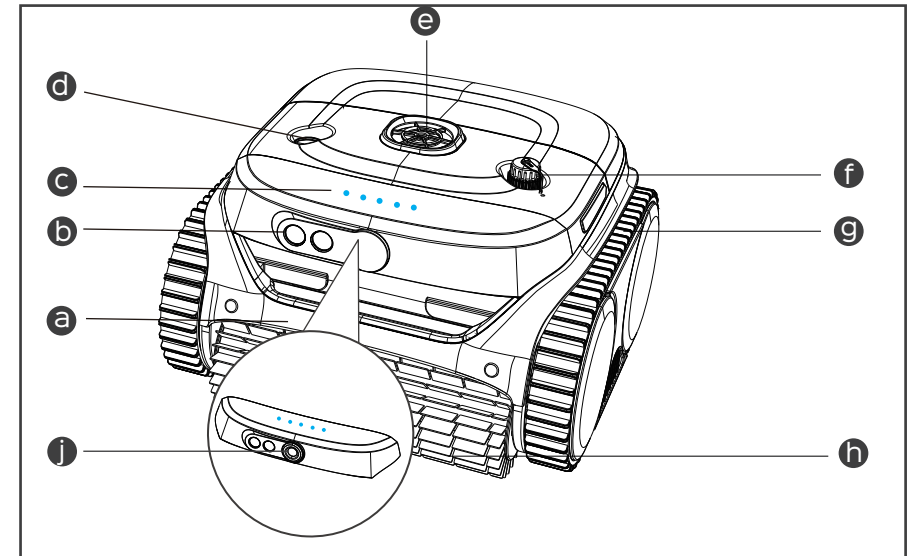

- | | |
|---|---|
| a Handle
Remove and transport the device with it | f Charging Port
Connect the charger to the cleaner |
| b Sonar Sensors
Detect and avoid obstacles in the pool | g Track
Enhance device's capability in climbing walls and various obstacles |
| c LED Indicator
Different light colors to indicate device status and current cleaning mode | h Scrubbing Brush
Knock loose all dirt and roll them all into the device |
| d On/off Button
Turn on/ turn off the device | i Camera (WYBOT C2PRO Vision)
Vision technology for high-efficiency cleaning |
| e Pump
Pump out water through the window | |

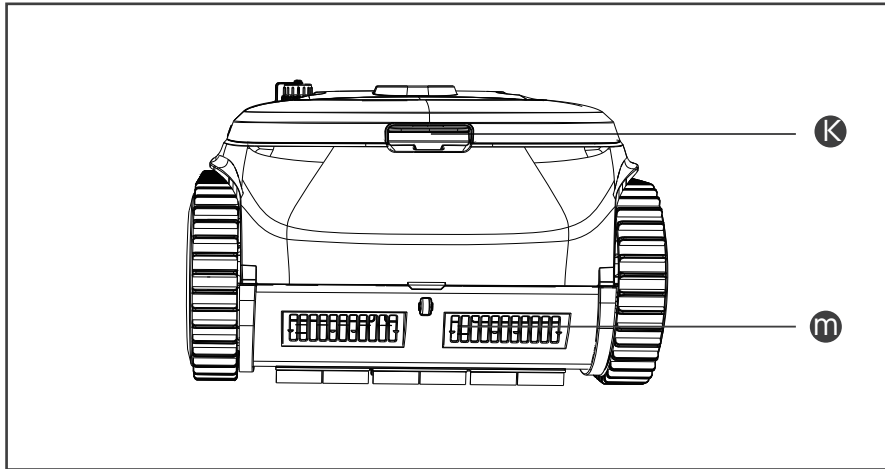

k Lid Open Button
Open the cover to take out the filters

m Water Outlet
Quick release of the water.

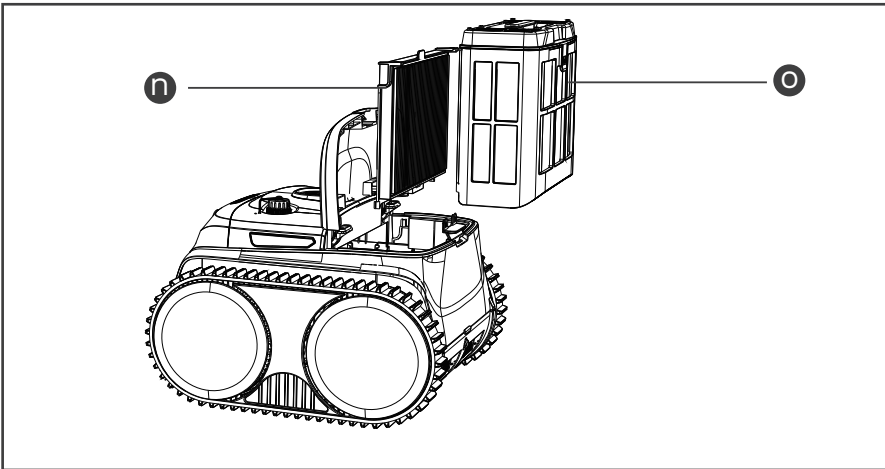

n Ultra-fine Filter
An auxiliary filter to help trap the fine dirty particles on the floor. Recommend to use it in 'turbo floor mode' only. Please do not install it when the floor is heavily soiled, it may influence the operation of the cleaner.

o Filter Basket
Store collected dirt and debris, remember to install it before start cleaning, and wash it after each use.

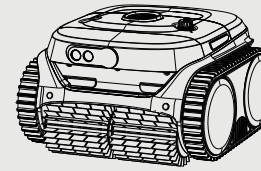

Device x 1

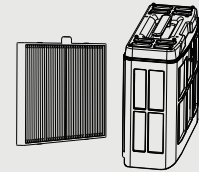

Filters x 2

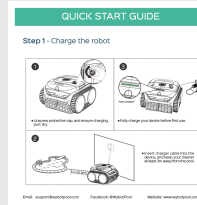

Quick Start Guide x 1



User Manual x 1

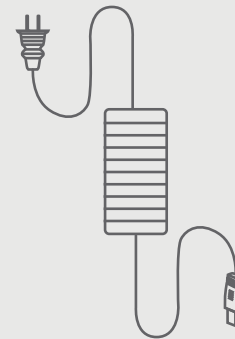

Charger x 1

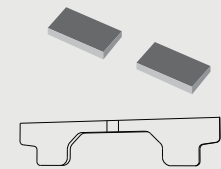

Floating Blocks

The device has a lithium-ion rechargeable battery, and you need to charge the battery before first use and when the battery is low.

Connect your device to a power outlet using the included cable and adaptor.

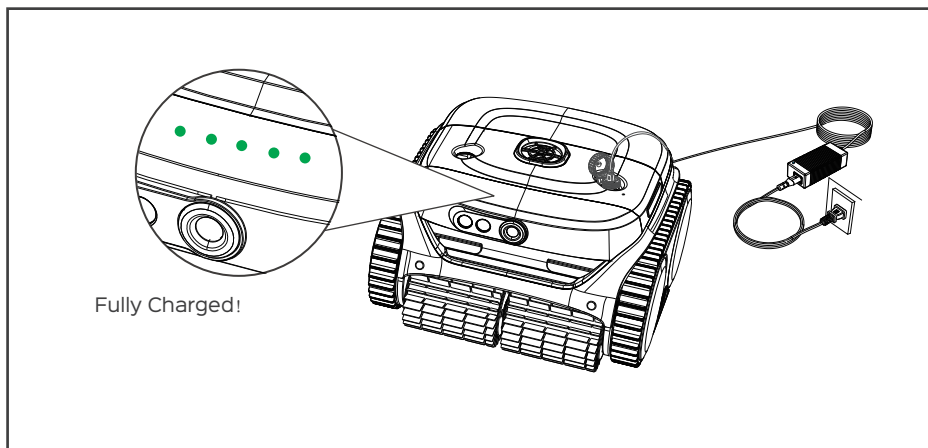

Note:

1. When charging, you should ensure your device at least 3m (appr. 10ft) away from the edge of the pool.
2. For reducing fire risk, keep your device and adaptor away from direct sunshine or water when charging.
3. For your important safety, you need to double check the device is powered off and the charging port is dry before charging.
4. The best charging environment is temperature at 32°F -95°F (0°C -35°C), RH at 5%-95%.

The adaptor has an indicator, which will display blue light ● indicating the power supply status.

The LED indicators on the top of the cleaner turn solid green light when fully charged.

Below is the indication of the LED lights, you may refer to it to know different device status.

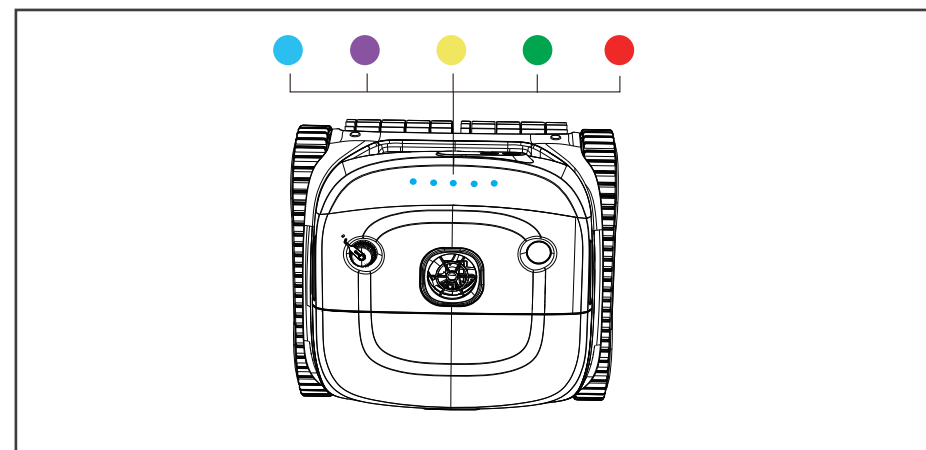

LED Light	Indication	Status
●	Solid	Power On
	Flashing	Under working
●	Solid	Connecting to App & Current cleaning mode
●	Flashing	Low battery or under self-parking in the pool
●	Flashing	Charging in progress
	Solid	Fully charged
●	Solid or flashing	Fault

Turn on the device by pressing the on/off button. The LED indicator on the top will display a solid green ● to display current battery level and then a solid blue ● when the device is on. If the battery level is too low to start cleaning, the LED lights will show a flashing ● .

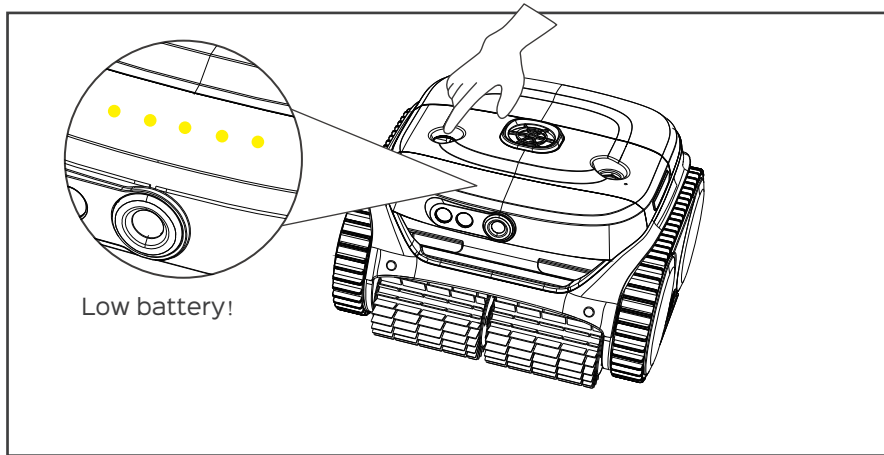

Note:

1. When yellow light flashes, you should charge the device immediately.
2. If red LED light is on, you can find solution from trouble shooting in this manual or call for service.

Connect to your App

You can download the WYBOT App to your smart mobile device by scanning QR code below, or from Google Play or App Store.



iOS	Android
iOS 15.0 or later	Android 8.0 or later

Choose your cleaning mode

You can choose a cleaning mode for your cleaner through the app after connecting to your App or pressing the 'on/off button'.

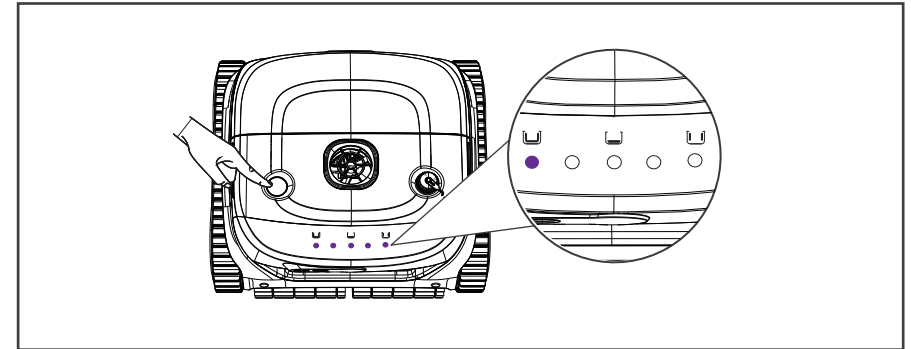

Cleaning Mode	Icon (Robot)	Cleaning Coverage
Standard full pool		Wall+ Floor+Waterline
Floor only		Pool floors
Wall only		Pool walls
Waterline only		Pool waterline
Wall then floor (Combo)		Wall *1+ Floor *1
Turbo floor		Powerful cleaning mode (floor cleaning only)
Eco floor		Eco mode, floor cleaning only
Dirt Hunting (Floor cleaning) (WYBOT C2 Vision only)		Vision-based cleaning path

Note:

1. You should modify your cleaning modes when out of pool. The default mode is Wall then floor
2. If the device restarts, it will automatically enter the cleaning mode you set last time.

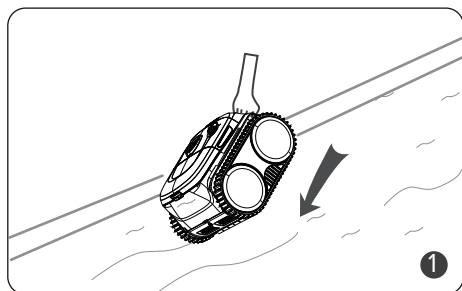

Hold the handle of the robot, and put it into the pool vertically.

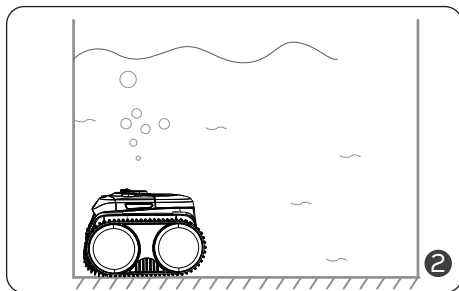

Let it sink down to the floor to empty trapped air inside.

Note:

To achieve an optimal cleaning performance, you should ensure the water depth of the pool is at least 19.5 in (50 cm) high from the top of the device.

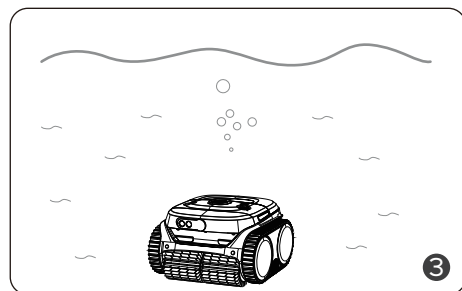

About 20 seconds of self-calibration, the indicator light will turn to be a flashing blue. The cleaner is ready to clean.

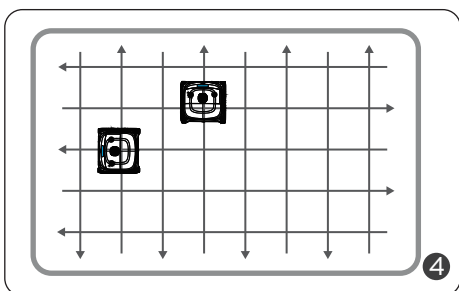

The cleaner begins to clean walls, floor and waterline as default or your set through App.

Dirt hunting mode (floor cleaning only)

If you have chose the dirt hunting cleaning mode through the APP, your cleaner will start cleaning floor in a high-efficiency cleaning path after entering the pool.

During the cleaning, the camera on the front of the cleaner will automatically detect and target for the dirt in front when has recognized them.

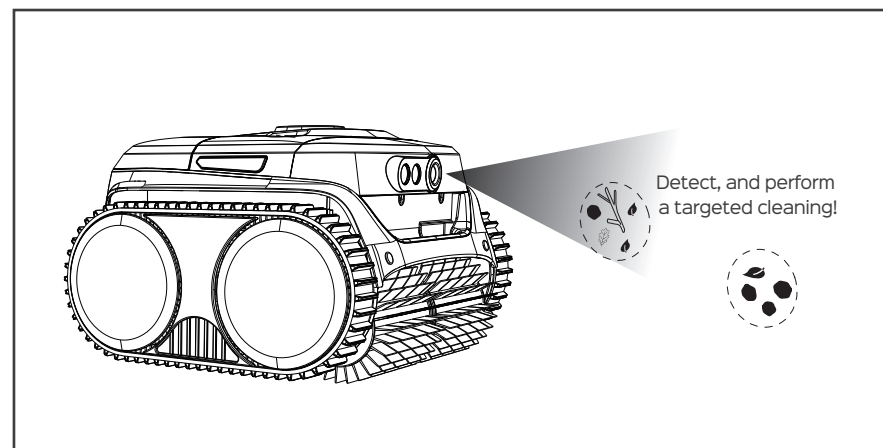

The robot needs to enrich its recognition of the dirt from the start, and it may turn on and record its floor dirt types during cleaning. It will reach its best targeted cleaning performance after one month of cleaning.

Your WYBOT continues enhancing its capability. Please help to update it to have the best cleaning experience.

Note:

1. The camera on the front is protected by a film when out of the factory, please peel it off if before running the "Dirt-hunting cleaning mode".
2. The camera on the robot will only be turned on when being underwater.
3. The dirt hunting cleaning mode is performed based on vision, thus the camera must be kept from any dust or scratch as it may decrease its performance.

02 / GET STARTED

Run your new WYBOT

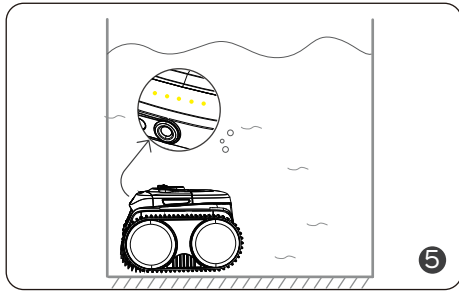

The device will automatically move to stop by the edge of wall when finishing cleaning or battery low.

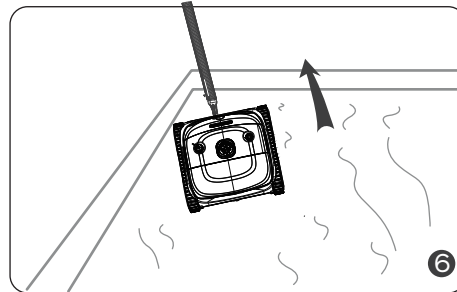

Insert the included hook into a pool pole and lift the cleaner out of the pool.

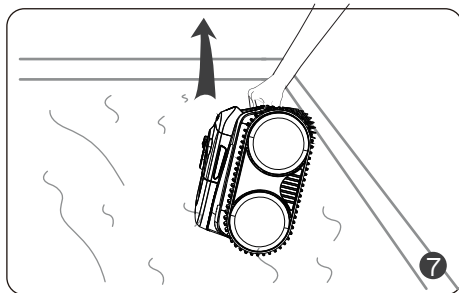

Take the cleaner out of the pool vertically to drain inside water out quickly.

03 / DO A FILTER CLEANING

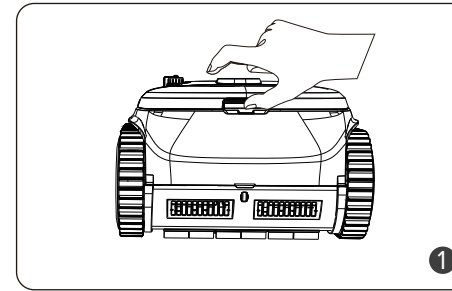

Push the lid open button up to open the cover.

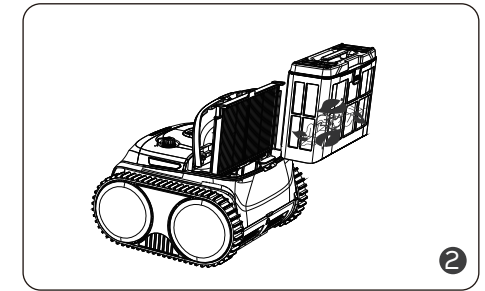

Take out the filter basket and HEPA.

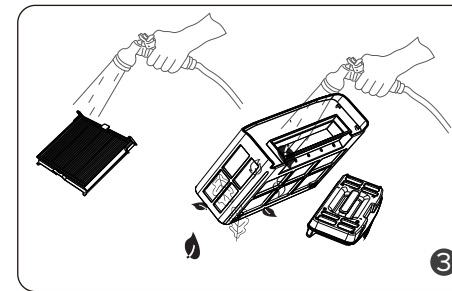

Empty all debris and rinse it with clean water.

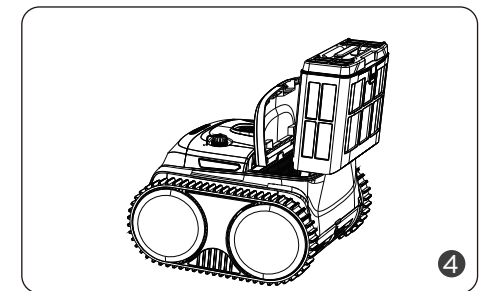

After rinsing, put the filter basket and cotton foam into the cleaner and close the cover.

Note:

1. As electric components inside the cleaner, store the cleaner in a cool and ventilated place, away from direct sunshine or any heat source.
2. Charge the cleaner prior to being stored for a long time (over 6 months) to maintain an optimal battery life.

04 / DEVICE SPECIFICATION

Model	WYBOT C2Pro	WYBOT C2Pro Vision
Pool Size	150m ²	150m ² ~180m ²
Min Water Depth	9.8ft (3m)	9.8ft (3m)
Device Dimension	360(L)*360(W)*240(H) mm	360(L)*360(W)*240(H) mm
Weight	8kg	8kg
Runtime	3 hours (Eco Floor)	3 hours (Eco Floor)
Charging Time	3 hours	3 hours
Power	65W	65W
Charger Input	100-240V, 50-60Hz	100-240V, 50-60Hz
Charger Output	25.2V/1.5A	25.2V/1.5A
Battery Capacity	4600mAh	4600mAh
Filtration	180µm+Ultra-fine filter	180µm+Ultra-fine filter
Moving Speed	10m/min	10m/min
Water Resistance	IPX8	IPX8
OTA upgrading	Available	Available
App Connection	Available	Available

05 / LIMITED WARRANTY

1. All WYBOT pool cleaners in the market have been inspected and licensed to be sold as per local laws.
2. The warranty applies only to original buyers, and not valid to resale and any other kinds of transfer.
3. Any damages to the unit caused by improper use, unauthorized repair or disassembly are not covered by WYBOTICS Co., Ltd.'s warranty.
4. The order number or record must be presented for any claim or repair within the warranty period.



Scan the QR code for the warranty policy.

06 / HOW TO MAINTAIN YOUR DEVICE

You should follow the steps to store your cleaner to maintain good performance.

- a) Ensure the device is power off
- b) Dry out the cleaner and filter drawer
- c) Fully charge the battery
- d) Store the cleaner in a cool and ventilated place, away from direct sunshine, heat source, frost and squeezing with an ambient temperature between 5°C / 41°F and 45°C / 113°F.
- e) Charge the cleaner every three months to ensure an optimal battery life.

Note:

If your device do not work after a long-term low battery life or being off, please contact after-sale team for help. For your safety, do not try to disassemble it without authorization.

07 / FAQ & TROUBLE SHOOTING

Q: What pool shapes and construction materials is the cleaner suitable for?

A: The machine can be applied to rectangle, oval, or irregular shapes of in-ground swimming pools. Applicable construction materials include PVC, gunite, tile and other materials. (Slippery materials such as tiles, mosaics, and acrylic may not work well, and you need to do some modification.)

Q: Will obstacles such as steps, shallow water areas, drains, slopes etc. in the swimming pool affect the running?

A: The machine can climb steps, drains, and shallow water areas. The above obstacles may influence its cleaning path, but will not affect the operation of the machine.

If you encounter the following situations when using the cleaner, you can check the table and solve them by yourself.

Note:

If you can not find a solution from the table, please contact after-sale team.

07 / FAQ & TROUBLE SHOOTING

No.	Issues	Details	Possible Causes	Suggested Solution
1	Device does not work	A solid red light	Impeller is stuck	Check the impeller and clean foreign
		A flashing red light	Motor protection	Restart
		A flashing red light	Not put the device into the water or the pool water is too shallow	Restart and put it into the pool immediately. Be sure the water depth is over 0.5m.
		A breathing yellow light	Battery low	Fully charge the device and restart
2	Unable to charge	Charger light flashes	Poor contact	Re-plug the charger
3	Do not climb walls	Slippery construction materials	Slippery construction materials	Stick adhesive blocks (Contact after-sale team for instruction)
		Too dirty water	Too dirty water	Clean the filter basket
4	Abnormal wall climbing	Climbing slowly	Filter basket blocked	Clean the filter basket
		Sinking down away from wall or floating on the water	Intake air	Stick adhesive blocks (Contact after-sale team for instruction)
			Filter basket blocked	Clean the filter basket
5	only clean part area and cannot clean the entire pool	Wrong cleaning mode	Wrong cleaning mode	Connect to the App and re-choose a suitable cleaning mode
		Firmware not latest	Firmware not latest	Connect to the App and update the firmware
6	front side up when on the floor	Filter basket blocked	Filter basket blocked	Clean the filter basket
7	Do not clean as set cleaning path	Encounter Obstacles	Encounter Obstacles	Clean the filter basket
	stuck at water drains	Drain height is over 3cm	Drain height is over 3cm	Help the machine away from the obstacle
	Unable to connect to the App	Device power off	Device power off	Restart
8	The APP cannot be connected when the device is in the pool	Not available	Not available	Connect the device on the shore

08 / CERTIFICATION

WYBOT robotic pool cleaners have passed all performance and reliability tests and also has obtained relevant certifications from the countries in which they are sold. you can rest assured.



09 / WYBOT CUSTOMER CARE

Due to the need for continuous products improvement, the products in the manual are subject to the real products, and WYBOTICS Co., Ltd. reserves the right to update products.

If you encounter any problems during use, please contact after-sale team.

For more details, please contact WYBOTICS website www.wybotpool.com

Wybot Customer Service:

Email: support@wybotpool.com

Facebook: @WybotPool

Tel: 1-866-777-6655



Scan the QR code for the e-Manual.