

GENERAL INSTALLATION AND MAINTENANCE MANUAL

**ORIGINAL
INSTRUCTIONS**

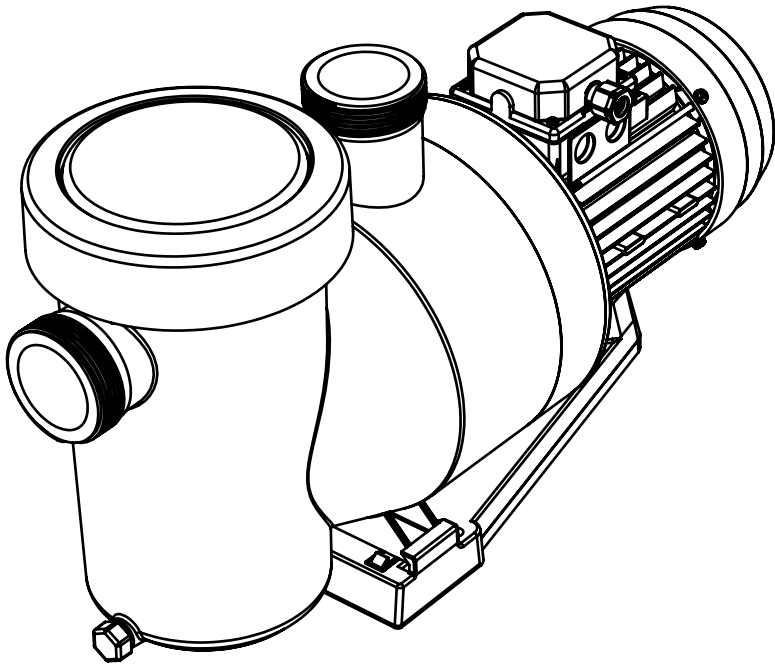

ASTRALPOOL



SELF-PRIMING PUMP FOR POOLS

TABLE OF CONTENTS

IMPORTANT SAFETY, INSTALLATION AND MAINTENANCE INFORMATION	3
1. GENERAL SAFETY WARNINGS.....	5
2. INSTALLATION	
2.1 SELECTING A LOCATION	5
2.2 HYDRAULIC PIPING	7
2.3 WIRING	9
3. USE	
3.1 OPERATING PRINCIPLE	11
3.2 OPERATION	11
4. MAINTENANCE.....	13
5. TROUBLESHOOTING	14



Recycling

This symbol is required by Directive 2012/19/EU of the European Parliament and of the Council on waste electrical and electronic equipment (WEEE). It means that this appliance must not be disposed of in a normal rubbish bin. It must be taken to a selective waste collection facility so that it can be reused, recycled or transformed and any substance that it contains that poses a potential hazard to the environment can be removed or neutralized. Ask your dealer for any information about recycling processes.

IMPORTANT SAFETY, INSTALLATION AND MAINTENANCE INFORMATION



This instruction manual contains essential information on the safety measures to be adopted during installation, maintenance and start-up. Therefore, both the installer and the end user must read all of these instructions very carefully before beginning the installation and start-up.

**The manual can be downloaded in PDF format at:
www.astralpoolmanuals.com.**



- The appliance described in this manual is specially designed for the pre-filtering and recirculation of water in swimming pools, with clean water at temperatures that do not exceed 35 °C.
- This appliance is not intended for use by persons (including children) with reduced physical, sensory or mental capabilities, or lack of experience and knowledge, unless they have been given supervision or instruction concerning use of the appliance by a person responsible for their safety. Children should be supervised to ensure that they do not play with the appliance.
- This appliance can be used by children aged from 8 years and above and persons with reduced physical, sensory or mental capabilities or lack of experience and knowledge if they have been given supervision or instruction concerning use of the appliance in a safe way and understand the hazards involved. Children must not play with this appliance. Cleaning and maintenance must not be carried out by children without supervision.



- Our pumps may only be assembled and installed in pools compliant with standards IEC/HD 60364-7-702 and required national rules. The installation should follow standard IEC/HD 60364-7-702 and required national rules for swimming pools. Consult your local dealer for more information.
- If a self-priming pump is to be fitted above the water level, the pressure differential to the pump suction pipe should not be higher than 0.015 MPa (1.5 mH₂O). Ensure that the suction pipe is as short as possible as a longer pipe would increase suction time and the installation's load losses.
- The pump is intended to be used while fastened to a support or while secured in a specific location in a horizontal position.

- Place a sump with an adequate outlet for the liquid where flooding is likely to occur.
- The pump cannot be installed in Zone 0 (Z0) or Zone 1 (Z1). To see drawings refer to page 6.
- See the maximum total head (H max), in meters on the back cover of the manual specific to each range of pump.
- The unit should be connected to an alternating current supply (see data on the pump's plate) with an earth connection, protected by a residual current device (RCD) with a rated residual operating current that does not exceed 30 mA.
- A disconnecter must be fitted to the fixed electrical installation in accordance to the installation regulations.
-  • Failure to heed the warnings can cause serious damage to the pool's equipment or serious injury, including death.
- Observe the regulations in force on accident prevention.
- Before handling the unit, ensure that the power supply is switched off and disconnected from the mains.
- If the unit breaks down, do not try to repair it yourself. Contact a qualified service engineer instead.
- All modifications to the pump require the manufacturer's prior authorization. Spare parts and original accessories authorized by the manufacturer ensure greater safety. The pump's manufacturer may not be held liable for any damage caused by unauthorized spare parts or accessories.
- Do not touch the fan or moving parts and do not place a rod or your fingers near the moving parts while the device is running. Moving parts can cause serious injury or even death.
- Do not dry-run the pump or without water (the warranty will become null and void).
- Do not do any maintenance or repair work on the device with wet hands or if the device is wet.
- Do not submerge the device in water or mud.

1. GENERAL SAFETY WARNINGS

These symbols (⚡ ⚠ ⚠) mean that there is a potential hazard as a result of not heeding the relevant warnings.



HAZARD. Risk of electrocution.

Disregarding this warning entails the risk of electrocution.



HAZARD.

Disregarding this warning entails the risk of harming people or damaging objects.



IMPORTANT.

Disregarding this warning entails the risk of damaging the pump or the installation.

2. INSTALLATION

2.1 SELECTING A LOCATION

The pump must be installed:

- Before the filter, heating system and/or water treatment unit.
- At a distance of 2 meters from the edge of the pool, to prevent water from splashing the unit. Some standards allow other distances. Consult the standards in force in the country of installation.
- Ideally, 30 cm below the water level.
- Outside an area susceptible to flooding or on a stand with drainage.
- In a well ventilated place, to allow the pump to cool.
- There must be easy access for maintenance work on the device.
- It is recommended to leave space between the pump and the outer edges of the installation as shown in the diagram (FIGURE 1).
- Place it on a stable, leveled and solid surface (e.g., concrete base).
- Fasten the pump to the ground using the anchoring stud so that it is suitably fitted in place. (FIGURE 2).

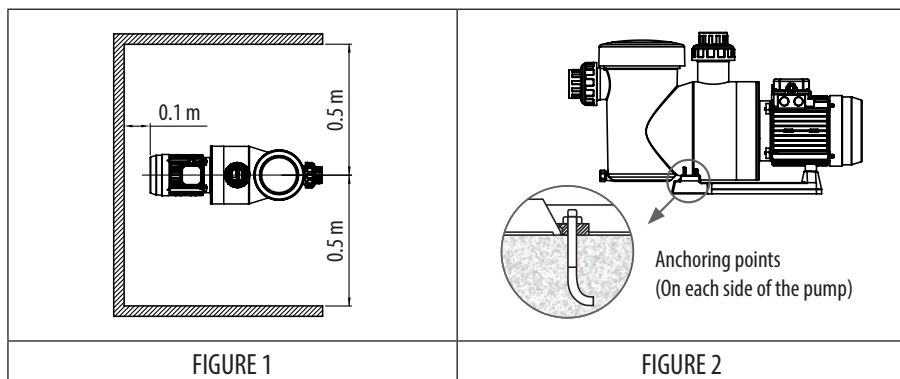

The pump must not be installed:

- In an area susceptible to rainfall and splashing.
- Near a heat source or source of inflammable gas.
- In an area that cannot be cleaned or kept free of leaves, dry vegetation and other inflammable items.
- In Zone 0 (Z0) and Zone 1 (Z1) (FIGURE 3).

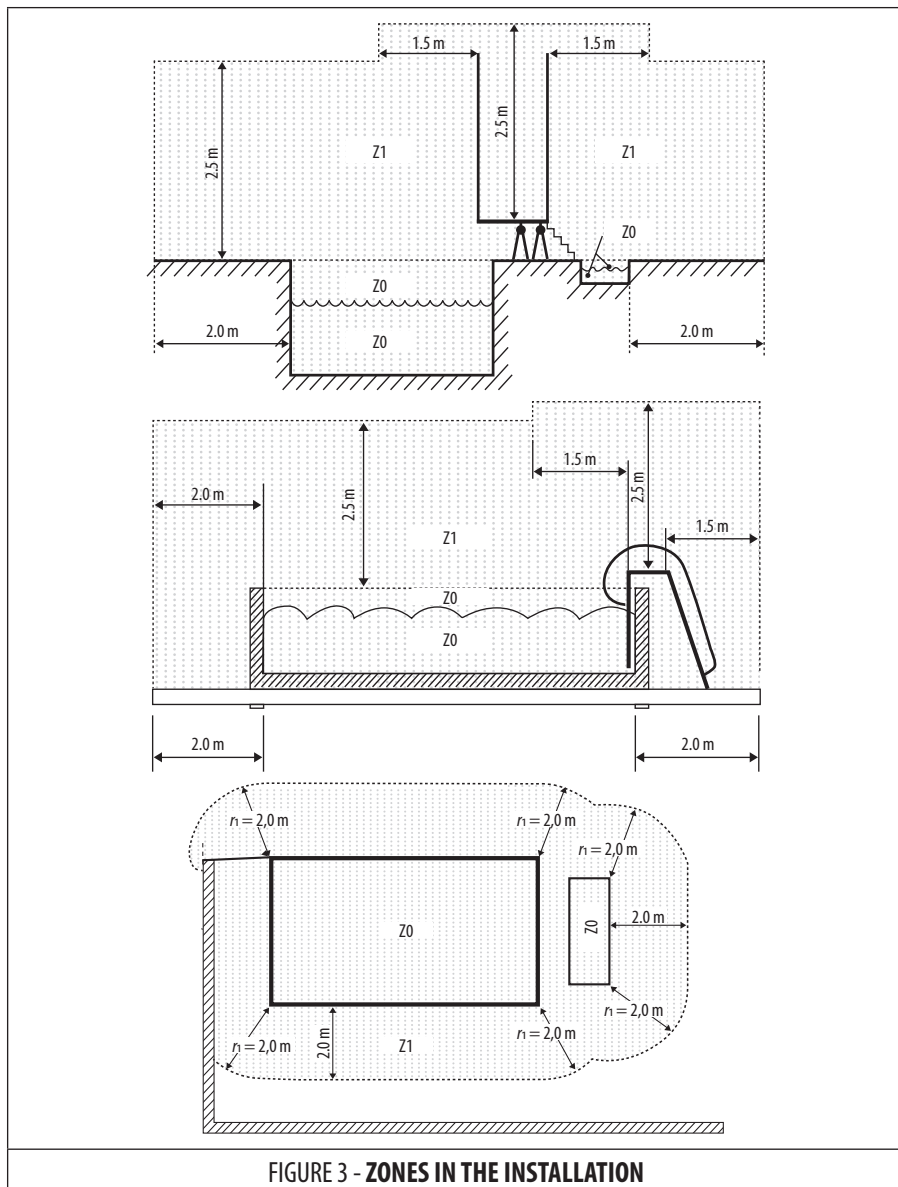
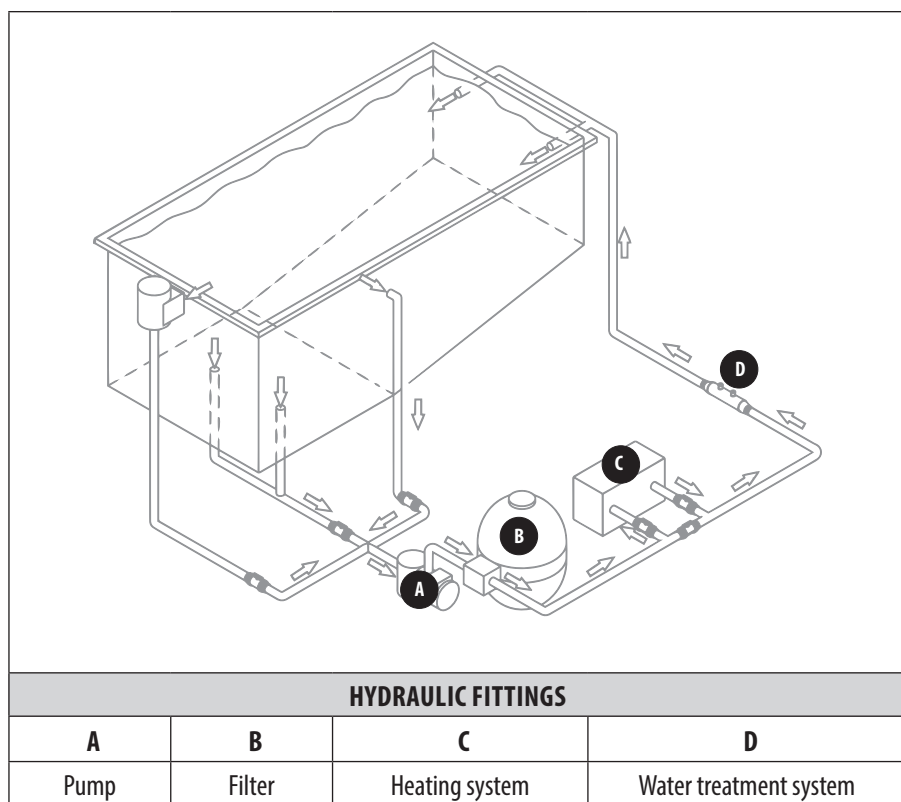



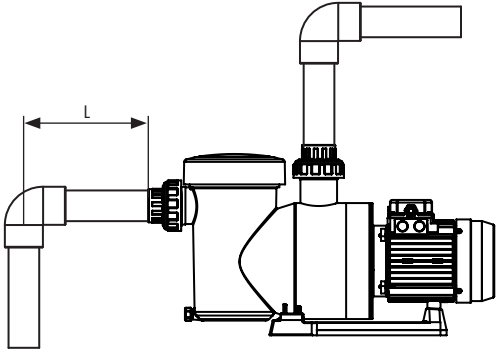

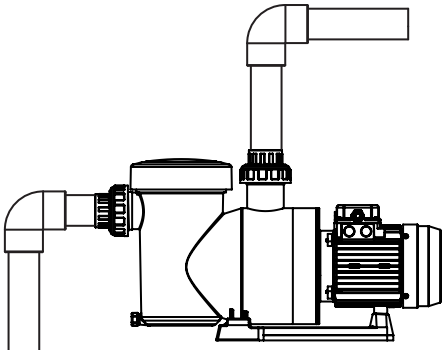

FIGURE 3 - ZONES IN THE INSTALLATION

2.2 HYDRAULIC PIPING

- Observe the direction of the hydraulic connections.
- Select the pipe size according to the size of the pool in line with the hydraulic standards in place in the country of installation.
- For hydraulic connections, use the standard connections required.
- Fit a check valve if the filter is installed above the water level.
- Fit isolation valves (suction and discharge) if the pump is installed below the water level.
- To avoid problems with priming, install the suction pipe so that there are no high points where air can build up.
- Check that the hydraulic connections are securely tightened and that there are no leaks.
- The piping should be well supported to avoid any risk of breakage due to the weight of the water.

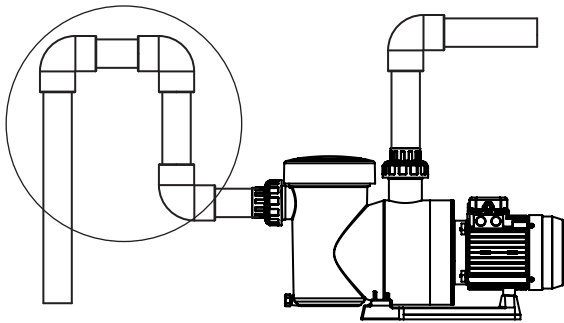

- Use as few elbow joints as possible. If there must be more than 10 elbow joints in the hydraulic circuit, the diameter of the piping must be increased.

	
<p>Length of the suction pipe (L) = 4 x \varnothing</p>	
	
<p>Suction pipe too short. Risk of cavitation</p>	
	
<p>Air entrapment. Risk of the pre-filter not filling properly</p>	

2.3 WIRING

- To avoid the terminal block from overheating (which could cause a fire), check that the terminals are securely fastened. Loose terminals will make the warranty null and void.



- Any unsuitable electrical connection will make the warranty null and void.

- The power cable must be insulated and protected against abrasion and damage.



- Turn the power off and install a ground connection before beginning work on the wiring.

1. Unscrew the screws to open the connection box. (FIGURE 4)
2. Disconnect and remove the factory test wires from the terminal block. (FIGURE 4)

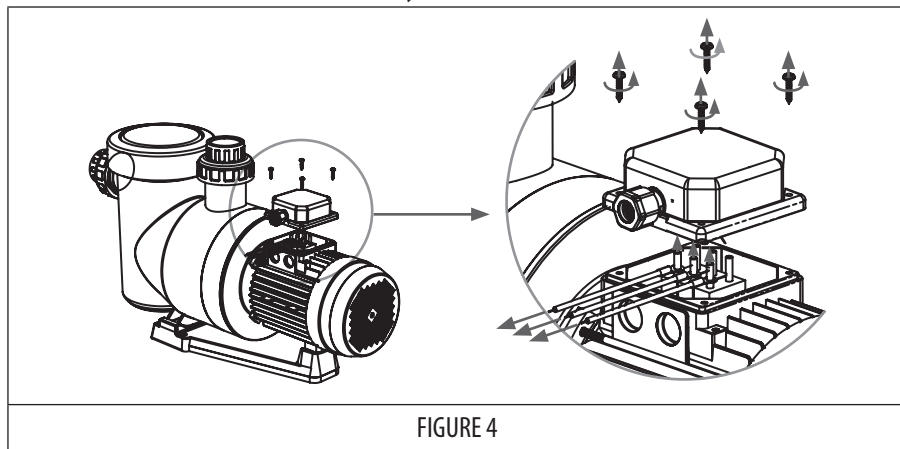

FIGURE 4

3. Run the power cable through the gland seal nut and tighten it. (FIGURE 5)

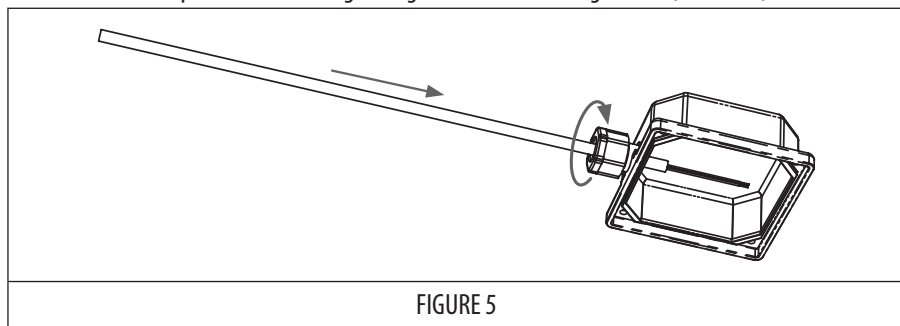

FIGURE 5

- The type of power cable used must be sheathed in polychloroprene or an equivalent synthetic elastomer and not be lighter than the cable's heavy-duty polychloroprene sheath (designation code 60245 IEC 66). However, pumps with a rated power of 1 CV or lower may be fitted with a standard-duty polychloroprene sheathed cable (designation code 60245 IEC 57).

4. Connect the wires as shown in the following diagrams (select as may be the case).

<p>Single-phase - 230 VAC-50 Hz</p>	
<p>Three-phase - 400 VAC-50Hz</p>	
<p>Three-phase - 230 VAC-50Hz</p>	
<p>Three-phase - 400 VAC-50Hz</p>	

5. Close the connection box, check that the seal is in place and tighten the screws. (FIGURE 6)

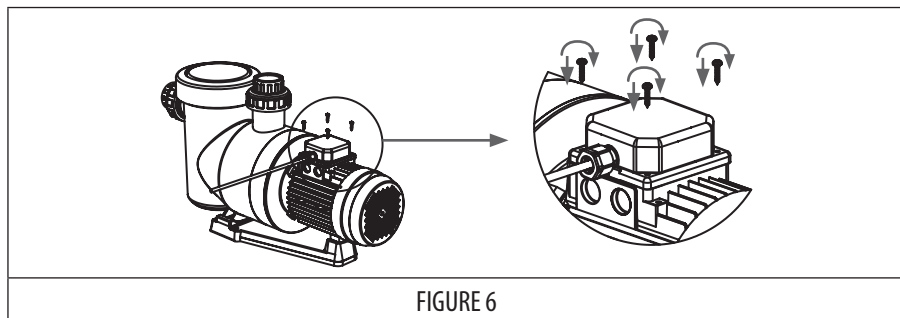

FIGURE 6

- In three-phase pumps, a variable-frequency drive may be installed.
- If a variable-frequency drive is used, installing an output filter is recommended to obtain the right supply voltage for the motor. This will lengthen the pump's service life.
- Adjust the variable-frequency drive as per the motor's rating plate. Adjusting overvoltages and overloads is not permitted.
- The variable-frequency drive's switching frequency must be set to values between 4–8 kHz. If outside of this range, the pump's service life will be shortened.
- For three-phase pumps, a protection device must be fitted (motor guard circuit breaker with magnetothermic protection) in the fixed electrical installation.

3. USE

3.1 OPERATING PRINCIPLE

The filter pump is an essential, core component of any pool, as it is used to circulate the water through all components, the filter in particular.

Its motor makes the turbine rotate, which pumps the water. The pre-filter basket collects the larger pieces of debris to prevent the turbine from becoming blocked or damaged.

3.2 OPERATION



- To prevent any risk of explosion that could cause material damage, serious injury or even death, ensure that the hydraulic circuit is free of obstructions, is not blocked and is not under high pressure.
- The cover of the pre-filter basket may be closed manually or by using the tool supplied with the pump.
- Check that the hydraulic connections are securely tightened.

- Check that the pump is stable and leveled.
- The hydraulic circuit should be drained and not contain any foreign bodies.
- The lid of the pre-filter basket must be properly closed (manually) and its seal clean and properly in place.
- Check that the valves are open.
- As the pump is self-priming, the pre-filter must be filled with water before starting it up for the first time in order to facilitate the process. (FIGURE 7).

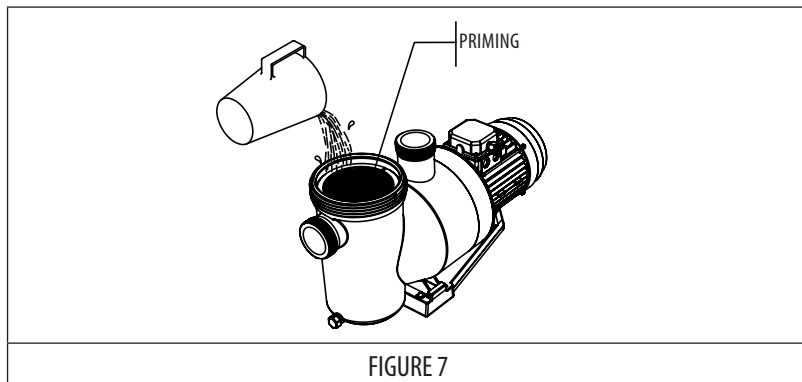

FIGURE 7

- The pump has a priming capacity of up to 1.5 meters above the water level of the pool at sea level (if the hydraulic circuit is properly sealed).
- Start the pump electrically.
- Bleed the air that may have built up in the filtration circuit using the drainage, which is usually on the filter (see the pool filter manual).
- Check that there are no leaks in the hydraulic circuit.
- Check that the motor is turning in the right direction (look at the fan located at the back of the motor). (FIGURE 8).

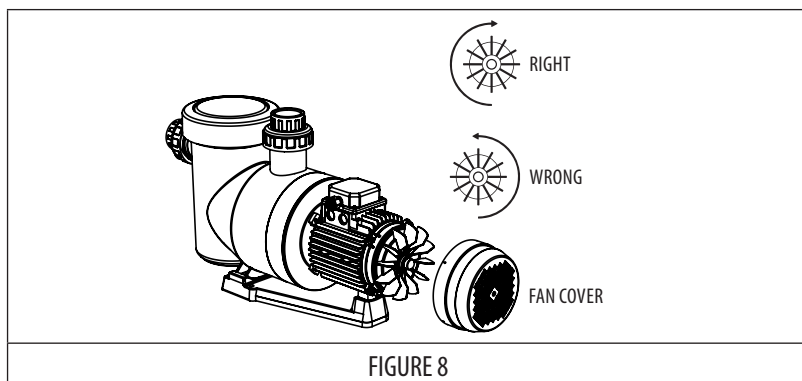

FIGURE 8

- Run the pump and from the pre-filter lid check that the pump is fully primed for no more than 12 minutes.
- The motor guard circuit breaker's current may not exceed the nominal value displayed on the pump's rating plate by more than 15%.
- The variable-frequency drive's output frequency range must be 20–50 Hz. The pump must not be used outside of this range.
- Check that all units installed in the pool are able to work properly when the pump is running at low speed (20 Hz).

4. MAINTENANCE

Depending on how clean the water is, the following should be checked every 150 hours:



- Clean the prefilter basket to avoid pressure drops. Do not hit the basket during the cleaning process as this could potentially damage it.
- Every time the prefilter is opened, clean off any dirt on the seal and its housing to ensure the cover is watertight when closed (FIGURE 9).

The pump components that are prone to wear and tear through routine use must be regularly replaced for the pump to maintain good performance. The pump's fungible components or consumables are listed in the table below along with the time when they should be replaced.

DESCRIPTION OF THE COMPONENT	REPLACEMENT TIME
Capacitor	10,000 h
Bearings	10,000 h
Mechanical seal	10,000 h
O-rings and other seals ⁽¹⁾	10,000 h

⁽¹⁾ Opening and closing the pump to replace internal parts does not guarantee subsequent water tightness. Therefore, it is recommended that O-rings and other seals be replaced whenever the mechanical seal and/or bearings are replaced.

The service life of the above components has been calculated based on the pump's normal conditions of use, installation and maintenance as described in this pump's manuals.

Follow the instructions in this pump's manuals to ensure it works properly.

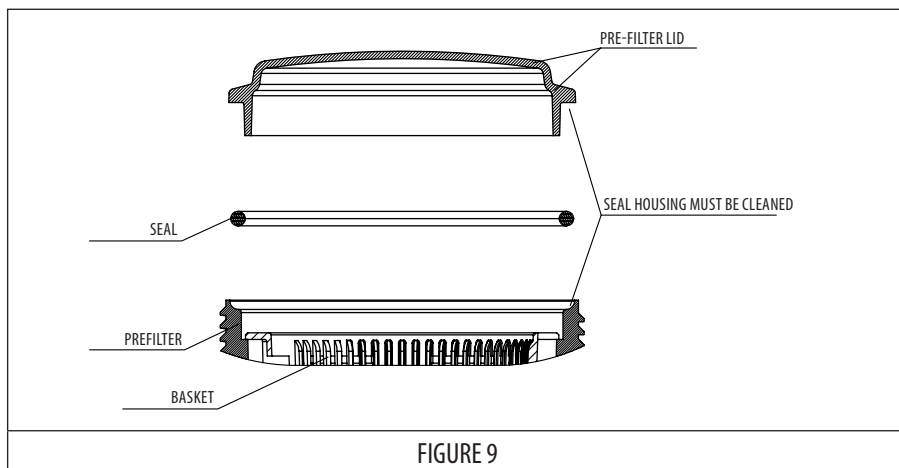



FIGURE 9

- If the pump stops, check that the motor's amp consumption reading while in operation is the same or below that displayed on the manufacturer's rating plate; in its absence contact your nearest Technical Assistance Service.
- 
- Drain the pump of water in the event that it will spend some time without running, mainly in cold countries where there is also a risk of freezing temperatures.
 - To drain the pump, remove the draining plug.

5. TROUBLESHOOTING



- If a problem arises, before contacting your dealer, make the following simple checks as described in the table below.
- If the problem persists, contact your dealer.
- The following may only be carried out by a qualified service personnel.

CAUSE	SOLUTION
The pump does not start/The motor does not turn.	<ul style="list-style-type: none"> • Power cut. Check the circuit breakers. • Check the connection between the power cable and the motor's terminals. • Check that the motor shaft is turning freely. Check that there is no debris in the pre-filter basket. • If any debris still remains, remove the pump to access the turbine.
The pump does not prime/There may be air in the pre-filter basket.	<ul style="list-style-type: none"> • Check the position and watertightness of the valves in the hydraulic circuit. • Air is trapped in the circuit. Bleed the hydraulic circuit (drainage on the filter). • The pool's water level is too low, so the circuit is sucking in air. Fill the pool. • The pre-filter lid is defective. Check the state of the seal and that the lid is watertight.
Low flow rate/Low filter pressure.	<ul style="list-style-type: none"> • The pre-filter basket is full of debris. Clean it. • Air leak in the circuit. Check all of the tightening torques. • The turbine and pump diffuser are blocked or worn. Replace them. • The diffuser's seal is worn. Replace it. • Reverse rotation of the motor (only on three-phase pumps). Check the connections of pump's terminal blocks.
Low flow rate/High filter pressure.	<ul style="list-style-type: none"> • The filter is blocked up. Wash the filter. • Check the position of the valves in the hydraulic circuit.
The pump makes a lot of noise.	<ul style="list-style-type: none"> • Air leak or cavitation in the suction piping. Check the position of the valves and adjust them whenever necessary. • Pump badly placed on the ground. Check that it is on a flat, hard, horizontal surface. Use anti vibration pads whenever necessary. • There is a foreign body in the pre-filter basket. • There is a foreign body in the body of the pump. The pump must be removed and taken for servicing.
Leak between the body of the pump and the motor.	<ul style="list-style-type: none"> • The mechanical seal is worn. Replace it. • The seal between the pump's body and flange is worn. Replace it.

Fluidra S.A.
Av. Alcalde Barnils, 69
08174 Sant Cugat del Vallés
(Barcelona) Spain

www.fluidra.com
©2022 Fluidra S.A. All rights reserved.

Code 05085-0010EN/ Rev. 00

We reserve the right to change all or part of the features of the articles or contents of this document, without prior notice.